

120t オールテレーンクレーン (TADANO ATF-120N-5.1)

■外観寸法

■アウトリガ張出幅・テールスイング

単位(mm)

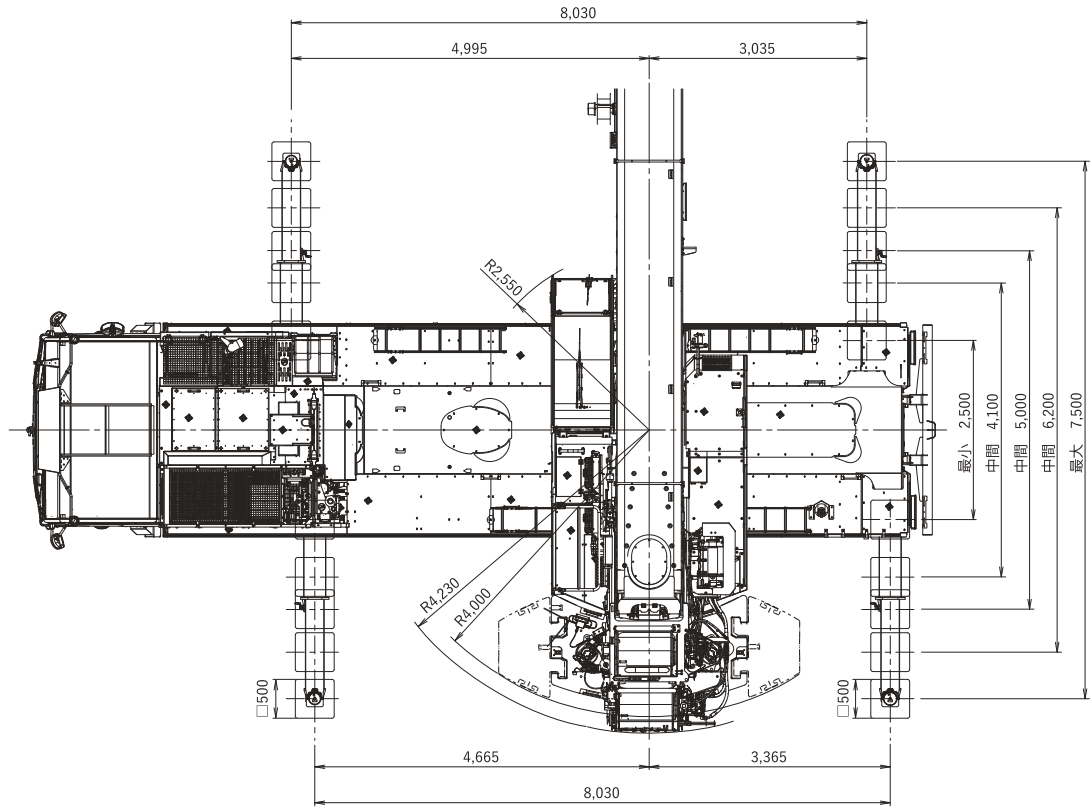

■構内移動姿勢

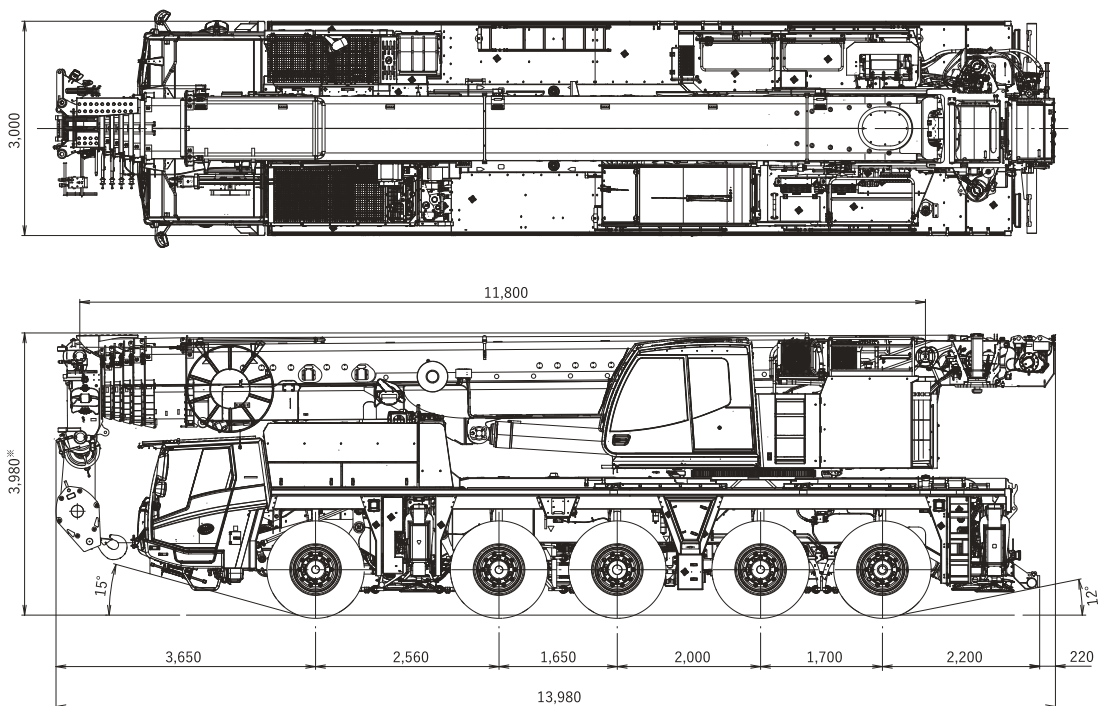

*+155mm、-120mm (サスペンション)

最低地上高：300mm

■ フック寸法

単位(mm)

H：ヘッドシーブ中心とハッカ上面の距離

	100tフック	60tフック	26tフック	8.7tフック
ブーム	2.9m	2.6m	2.6m	
シングルトップ				2.3m
1.1m+2.6m HLJ		2.6m	2.6m	
1.1m+9.0m HLJ			3.1m	3.1m
上記以外 HLJ				2.9m
FLJ				3.4m

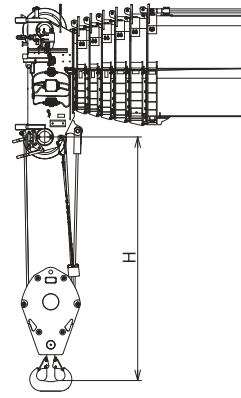

■ フック

100tフック 1.12 t × 2個

60tフック 0.6 t

26tフック 0.45 t

8.7tフック 0.3 t

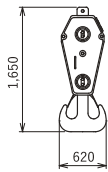

幅 700

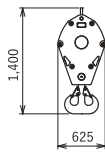

幅 355

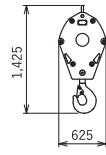

幅 235

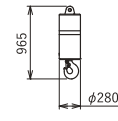

幅 280

■ カウンタウエイト(C/W)組合せ

●各ウエイトの使用個数を示す

合計重量	ウエイト ① 2.7t	ウエイト ② 3.5t	ウエイト ③ 3.4t	ウエイト ④ 2.3t	ウエイト ⑤ 3.4t	ウエイト ⑥ 3.4t	ウエイト ⑦ 4.0t	ウエイト ⑧ 5.7t
34.1 t	1	1	1	1	1	1	1	2
22.7 t	1	1	1	1	1	1	1	
18.7 t	1	1	1	1	1	1		
15.3 t	1	1	1	1	1			
11.9 t	1	1	1	1				
9.6 t	1	1	1					
6.2 t	1	1						

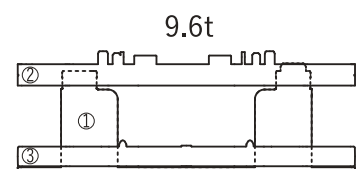
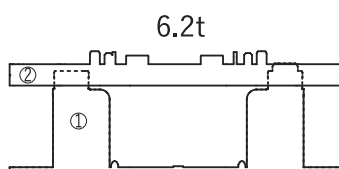
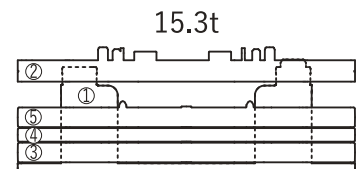
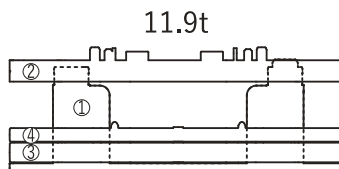
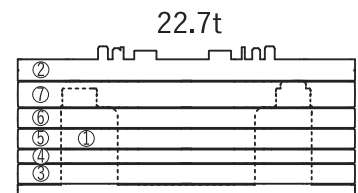
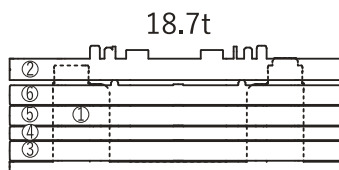
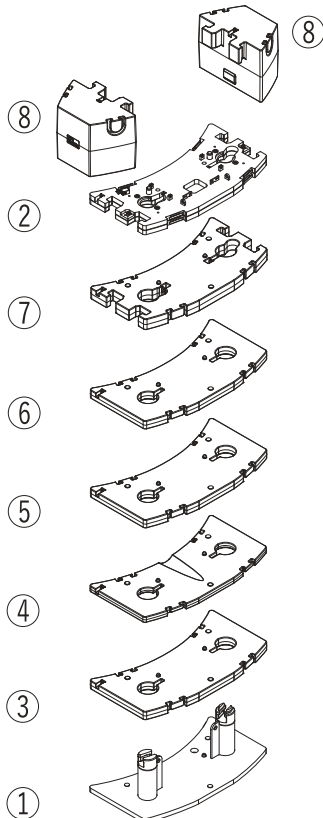
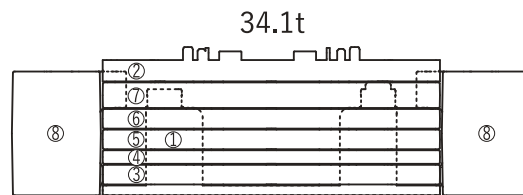

構成図

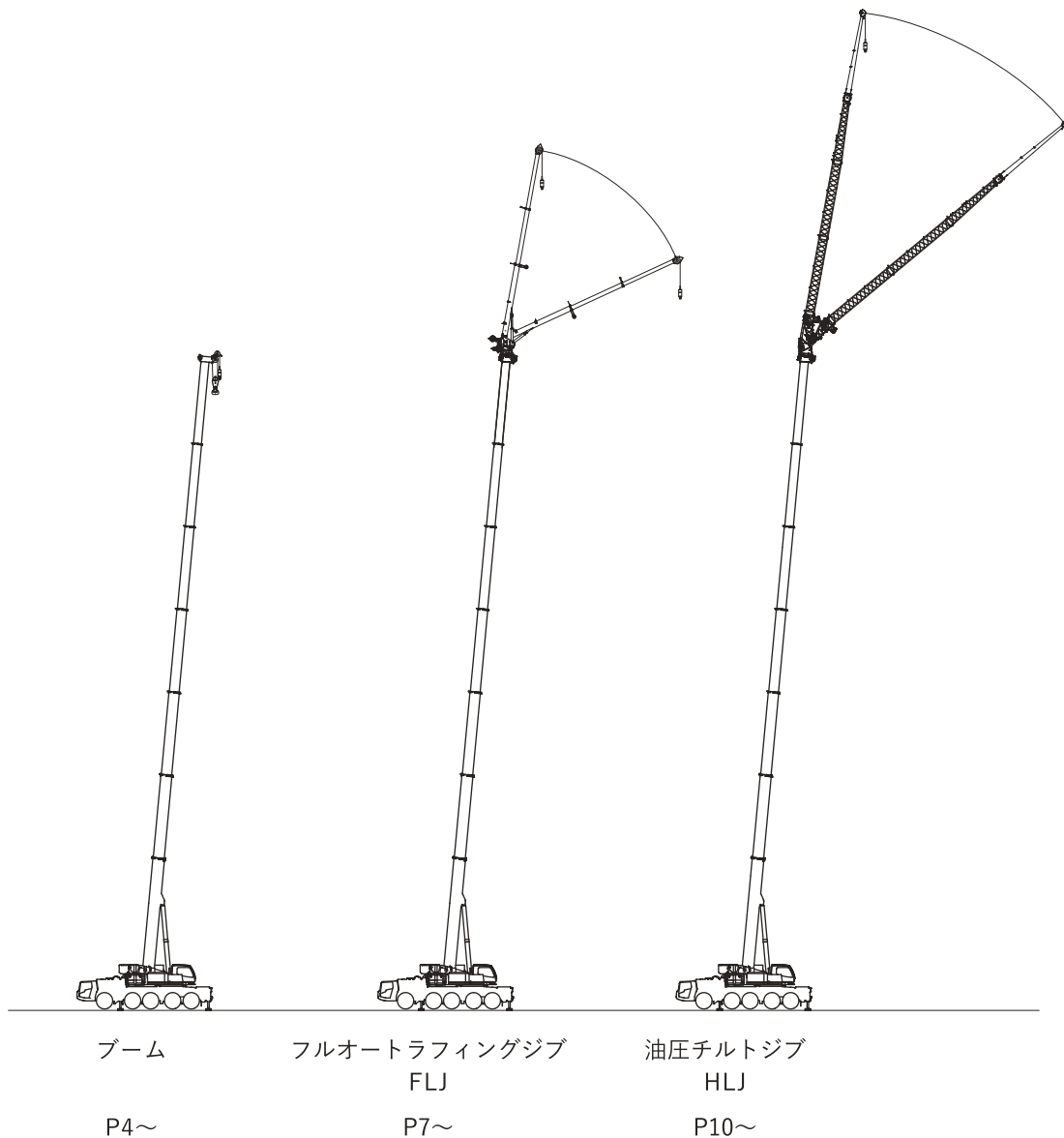

■ 定格総荷重表注意事項

- ◆ 定格総荷重は、つり具質量とフック質量（100t フック：1,120kg、60t フック：600kg、26t フック：450kg、8.7t フック：300kg）を含んだ値を示します。
- ◆ 定格総荷重は、ブームのたわみを含んだ実際の作業半径に基づいています。
- ◆ 各状態ごとの標準巻掛本数は別冊の仕様書を参照してください。
- ◆ シングルトップ使用時の巻掛本数は1本（8.7t フック使用）で、定格総荷重はブームの定格総荷重からブームに取り付けられているフックの質量を差し引いた値とし、かつ上限は8.7tです。
- ◆ 定格総荷重はアウトリガを水平堅土上に設置したときの値です。
- ◆ 定格総荷重表は、風による影響を含んでいません。瞬間最大風速が10m/s以上の風速では、クレーン作業を中止してください。

■メインブーム作業半径－揚程図

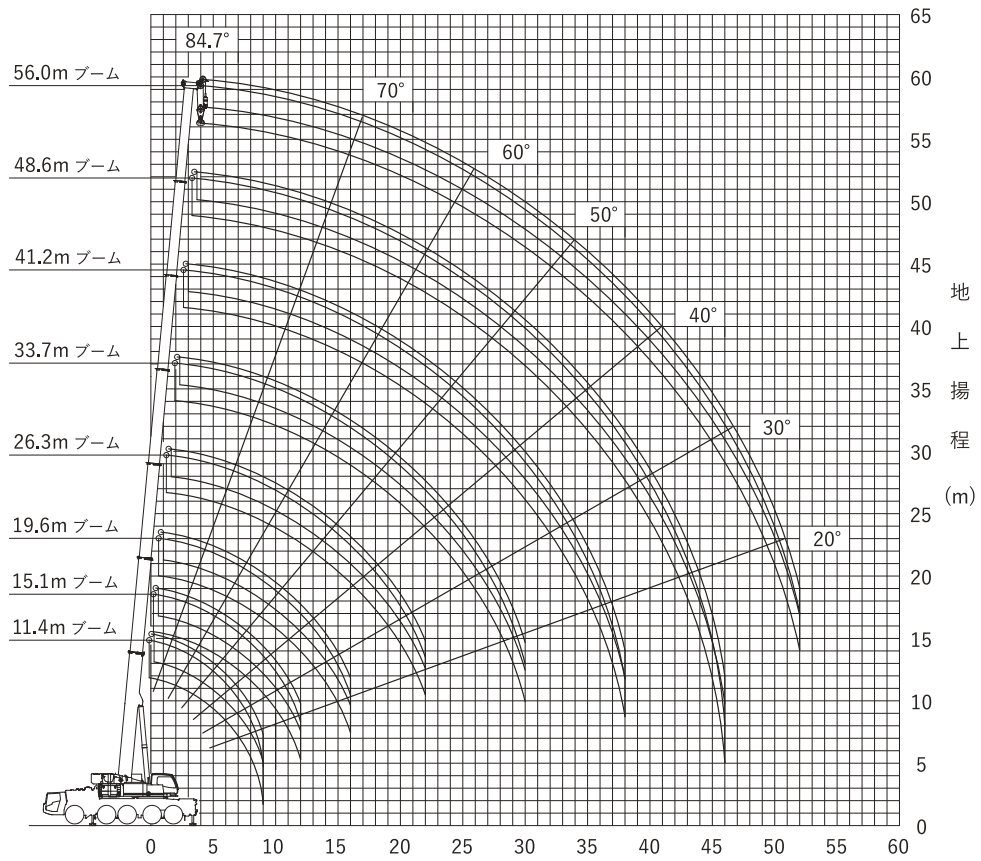



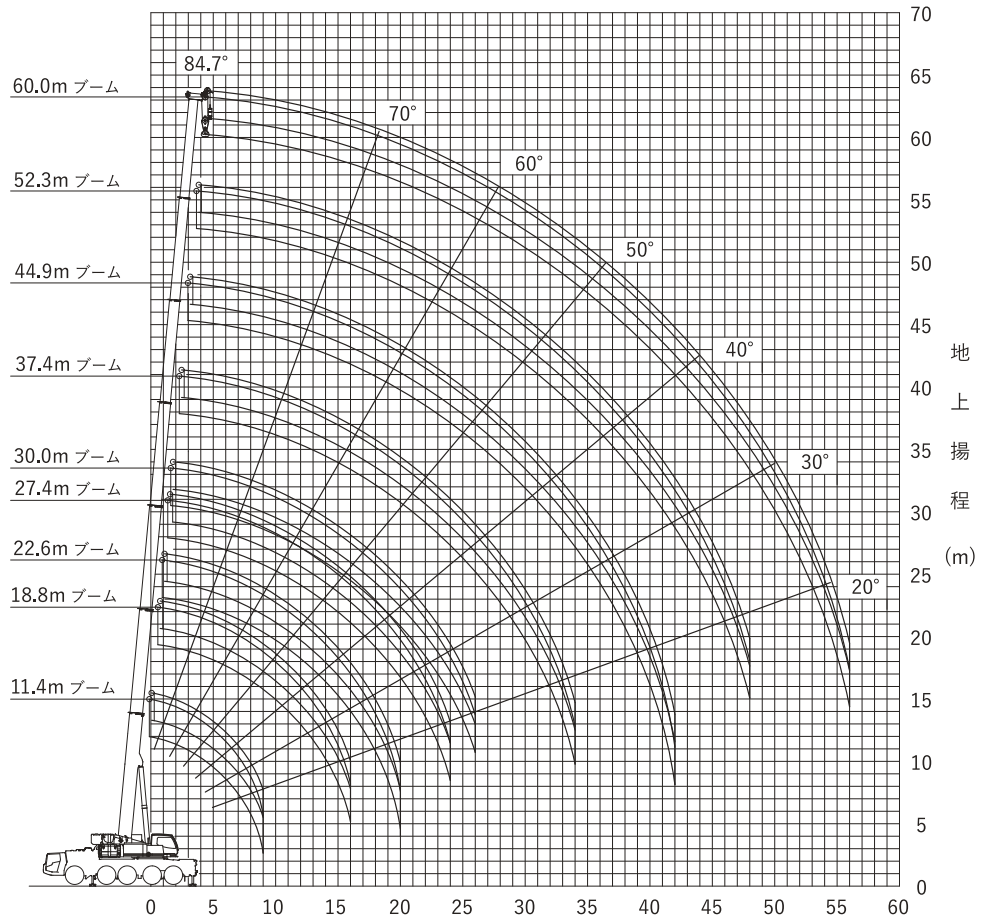



- (注意) 1. 上図はブームのたわみを含んでいません。 作業半径 (m)
2. カウンタウエイト34.1t、アウトリガ張出幅7.5m時の性能を図示しています。





- (注意) 1. 上図はブームのたわみを含んでいません。 作業半径 (m)
2. カウンタウエイト34.1t、アウトリガ張出幅7.5m時の性能を図示しています。

■メインブーム定格総荷重表

 MB	 34.1 t	 8.0m x 7.5m	 360°	 JPN
--	--	---	--	---

 m	※11.4	11.4	15.1	18.8	22.6	26.3	30.0	33.7	37.4	41.2	44.9	48.6	52.3	56.0	60.0	m
2.5	120.0	113.9	63.5	63.5	59.7											2.5
3.0	105.3	102.9	63.5	63.5	59.7	46.3										3.0
3.5	96.7	93.6	63.5	63.5	59.7	46.3	36.9									3.5
4.0	84.8	84.8	63.5	63.5	59.6	46.3	36.9									4.0
4.5	75.0	75.0	63.5	63.5	59.6	46.3	36.9	29.3	23.8							4.5
5.0	67.1	67.1	63.5	63.5	59.6	46.3	36.9	29.3	23.8	19.1						5.0
6.0	55.2	55.2	55.3	55.5	55.5	45.2	36.9	29.3	23.8	19.1	16.0					6.0
7.0	46.7	46.7	46.8	47.3	47.1	44.6	34.4	29.3	23.8	19.1	16.0	12.5				7.0
8.0	40.2	40.2	40.3	40.8	40.6	40.2	34.4	28.6	23.8	19.1	16.0	12.5	10.3	8.4		8.0
9.0	35.2	35.2	35.3	35.8	36.4	36.1	34.4	27.7	23.7	19.1	16.0	12.5	10.3	8.4	7.3	9.0
10.0			31.2	32.2	32.3	32.1	31.6	27.6	22.4	19.1	16.0	12.5	10.3	8.4	7.3	10.0
11.0			27.9	28.9	29.0	28.7	28.3	26.1	21.9	19.1	16.0	12.5	10.3	8.4	7.3	11.0
12.0			25.1	26.2	26.2	25.9	25.5	24.8	21.9	18.2	15.9	12.5	10.3	8.4	7.3	12.0
14.0				21.8	21.8	21.6	21.3	21.6	19.7	17.6	14.6	12.5	10.3	8.4	7.3	14.0
16.0				18.5	18.5	18.3	18.8	18.3	17.8	16.0	14.3	12.3	10.3	8.4	7.3	16.0
18.0					15.9	16.4	16.1	15.7	15.6	14.6	13.3	11.3	10.3	8.4	7.3	18.0
20.0					14.1	14.3	14.0	13.6	13.5	13.4	12.2	11.1	9.5	8.4	7.3	20.0
22.0						12.6	12.3	12.3	11.8	11.8	11.3	10.3	9.2	8.4	7.3	22.0
24.0							10.9	10.9	10.4	10.4	10.5	9.5	9.0	7.8	7.2	24.0
26.0							9.8	9.7	9.3	9.2	9.6	8.9	8.4	7.2	6.7	26.0
28.0								8.6	8.8	8.5	8.4	8.3	7.8	6.7	6.3	28.0
30.0								7.7	8.0	8.0	7.5	7.5	7.3	6.3	5.9	30.0
32.0									7.2	7.2	6.7	6.6	6.9	5.9	5.5	32.0
34.0									6.5	6.4	6.4	6.1	6.2	5.5	5.1	34.0
36.0										5.8	6.0	5.7	5.5	5.1	4.8	36.0
38.0										5.2	5.5	5.2	4.9	4.6	4.5	38.0
40.0											5.0	4.7	4.4	4.1	4.1	40.0
42.0											4.5	4.2	4.0	3.6	3.6	42.0
44.0												3.8	3.6	3.2	3.1	44.0
46.0												3.5	3.2	2.8	2.7	46.0
48.0													2.8	2.4	2.4	48.0
50.0														2.1	2.0	50.0
52.0														1.8	1.7	52.0
54.0															1.4	54.0
56.0															1.2	56.0





※は旋回位置が後方限定の性能を示しています。

 MB	 22.7 t	 8.0m x 7.5m	 360°	 JPN
--	--	---	--	---

 m	※11.4	11.4	15.1	18.8	22.6	26.3	30.0	33.7	37.4	41.2	44.9	48.6	52.3	56.0	60.0	m
2.5	114.7	113.1	63.5	63.5	59.7											2.5
3.0	105.1	101.9	63.5	63.5	59.7	46.3										3.0
3.5	90.3	90.3	63.5	63.5	59.7	46.3	36.9									3.5
4.0	78.7	78.7	63.5	63.5	59.6	46.3	36.9									4.0
4.5	69.5	69.5	63.5	63.5	59.6	46.3	36.9	29.3	23.8							4.5
5.0	62.2	62.2	61.9	61.4	59.6	46.3	36.9	29.3	23.8	19.1						5.0
6.0	51.1	51.1	51.2	51.7	51.5	45.2	36.9	29.3	23.8	19.1	16.0					6.0
7.0	43.1	43.1	43.2	43.7	43.5	43.2	34.4	29.3	23.8	19.1	16.0	12.5				7.0
8.0	37.1	37.1	37.2	37.7	38.3	38.1	34.4	28.6	23.8	19.1	16.0	12.5	10.3	8.4		8.0
9.0	32.5	32.5	32.5	33.6	33.6	33.3	32.9	27.7	23.7	19.1	16.0	12.5	10.3	8.4	7.3	9.0
10.0			28.7	29.8	29.8	29.6	29.1	27.6	22.4	19.1	16.0	12.5	10.3	8.4	7.3	10.0
11.0			26.0	26.6	26.6	26.4	25.9	26.1	21.9	19.1	16.0	12.5	10.3	8.4	7.3	11.0
12.0			23.5	23.9	23.9	23.7	23.5	23.8	21.9	18.2	15.9	12.5	10.3	8.4	7.3	12.0
14.0				19.7	19.7	19.8	20.0	19.6	19.5	17.6	14.6	12.5	10.3	8.4	7.3	14.0
16.0				16.2	16.3	16.8	16.5	16.5	15.8	15.8	14.3	12.3	10.3	8.4	7.3	16.0
18.0					14.0	13.9	13.5	13.6	12.9	12.9	13.3	11.3	10.3	8.4	7.3	18.0
20.0					11.8	11.7	11.3	11.3	11.4	11.1	11.2	11.1	9.5	8.4	7.3	20.0
22.0						10.0	9.6	9.6	10.0	10.0	9.5	9.5	9.2	8.4	7.3	22.0
24.0							8.3	8.3	8.6	8.6	8.5	8.6	8.4	7.8	7.2	24.0
26.0							7.2	7.1	7.5	7.5	7.8	7.5	7.2	6.9	6.7	26.0
28.0								6.2	6.5	6.5	6.8	6.5	6.3	5.9	5.9	28.0
30.0								5.4	5.7	5.7	6.0	5.7	5.5	5.1	5.1	30.0
32.0									5.1	5.1	5.3	5.0	4.8	4.4	4.3	32.0
34.0									4.5	4.5	4.7	4.4	4.2	3.7	3.7	34.0
36.0										3.9	4.2	3.9	3.6	3.1	3.1	36.0
38.0										3.4	3.7	3.3	3.1	2.6	2.6	38.0
40.0											3.3	2.9	2.6	2.2	2.1	40.0
42.0											2.9	2.5	2.2	1.8	1.7	42.0
44.0												2.1	1.8	1.4	1.4	44.0
46.0												1.8	1.5	1.1	1.0	46.0
48.0													1.2	0.8	0.7	48.0
50.0														0.5	0.5	50.0





※は旋回位置が後方限定の性能を示しています。

■メインブーム定格総荷重表

 MB	 11.9 t	 8.0m x 7.5m	 360°	 JPN
---	---	--	---	--

		※11.4	11.4	15.1	18.8	22.6	26.3	30.0	33.7	37.4	41.2	44.9	48.6	52.3	56.0	60.0		
 m	2.5	114.7	111.6	63.5	63.5	59.7												2.5
	3.0	97.5	97.5	63.5	63.5	59.7	46.3											3.0
	3.5	83.2	83.2	63.5	63.5	59.7	46.3	36.9										3.5
	4.0	72.4	72.4	63.5	63.5	59.6	46.3	36.9										4.0
	4.5	64.0	64.0	63.5	63.2	59.6	46.3	36.9	29.3	23.8								4.5
	5.0	57.2	57.2	57.3	56.4	56.7	46.3	36.9	29.3	23.8	19.1							5.0
	6.0	46.9	46.9	47.0	47.6	47.4	45.2	36.9	29.3	23.8	19.1	16.0						6.0
	7.0	39.5	39.5	39.6	40.1	39.9	39.7	34.4	29.3	23.8	19.1	16.0	12.5					7.0
	8.0	33.8	33.8	33.9	35.0	35.0	34.8	34.3	28.6	23.8	19.1	16.0	12.5	10.3	8.4			8.0
	9.0	29.2	29.2	29.8	30.4	30.4	30.2	29.7	27.7	23.7	19.1	16.0	12.5	10.3	8.4	7.3		9.0
	10.0			26.2	26.7	26.8	26.4	26.3	26.3	22.4	19.1	16.0	12.5	10.3	8.4	7.3	10.0	
	11.0			21.9	22.5	22.5	23.3	22.9	22.3	21.9	19.1	16.0	12.5	10.3	8.4	7.3	11.0	
	12.0			18.9	19.2	20.1	20.0	19.6	19.7	18.9	18.2	15.9	12.5	10.3	8.4	7.3	12.0	
	14.0				15.2	15.4	15.3	14.9	15.0	14.7	14.4	14.6	12.5	10.3	8.4	7.3	14.0	
	16.0				12.0	12.2	12.1	11.8	11.8	12.2	12.3	11.6	11.3	10.3	8.4	7.3	16.0	
	18.0					10.0	9.8	9.5	9.5	9.9	10.0	10.2	9.9	9.2	8.4	7.3	18.0	
	20.0						8.3	8.1	7.8	8.2	8.2	8.5	8.2	8.0	7.6	7.3	20.0	
	22.0							6.8	6.4	6.4	6.8	6.9	6.9	6.6	6.1	6.1	22.0	
	24.0								5.3	5.3	5.7	5.7	6.1	5.7	4.9	4.9	24.0	
	26.0								4.4	4.3	4.8	4.8	5.1	4.7	4.4	4.0	26.0	
	28.0									3.5	4.0	4.0	4.3	3.9	3.6	3.2	28.0	
30.0									2.9	3.3	3.3	3.6	3.3	3.0	2.5	30.0		
32.0										2.7	2.7	3.0	2.7	2.4	1.9	32.0		
34.0										2.2	2.2	2.5	2.2	1.9	1.4	34.0		
36.0											1.8	2.1	1.7	1.4	1.0	36.0		
38.0											1.4	1.7	1.3	1.0	0.6	38.0		
40.0												1.4	1.0	0.7		40.0		
42.0												1.1	0.7			42.0		

※は旋回位置が後方限定の性能を示しています。

 MB	 9.6 t	 8.0m x 7.5m	 360°	 JPN
---	--	--	---	--

		※11.4	11.4	15.1	18.8	22.6	26.3	30.0	33.7	37.4	41.2	44.9	48.6	52.3	56.0	60.0		
 m	2.5	114.4	111.3	63.5	63.5	59.7												2.5
	3.0	95.8	95.8	63.5	63.5	59.7	46.3											3.0
	3.5	81.7	81.7	63.5	63.5	59.7	46.3	36.9										3.5
	4.0	71.1	71.1	63.5	63.5	59.6	46.3	36.9										4.0
	4.5	62.8	62.8	62.5	62.1	59.6	46.3	36.9	29.3	23.8								4.5
	5.0	56.1	56.1	56.3	55.5	55.7	46.3	36.9	29.3	23.8	19.1							5.0
	6.0	46.0	46.0	46.1	46.7	46.5	45.2	36.9	29.3	23.8	19.1	16.0						6.0
	7.0	38.7	38.7	38.8	39.7	39.7	39.7	34.4	29.3	23.8	19.1	16.0	12.5					7.0
	8.0	32.9	32.9	33.0	34.2	34.2	34.0	33.5	28.6	23.8	19.1	16.0	12.5	10.3	8.4			8.0
	9.0	28.5	28.5	29.3	29.7	29.7	29.4	29.0	27.7	23.7	19.1	16.0	12.5	10.3	8.4	7.3		9.0
	10.0			24.3	24.9	24.9	24.7	25.4	24.7	22.4	19.1	16.0	12.5	10.3	8.4	7.3	10.0	
	11.0			20.2	20.8	21.3	21.6	21.2	21.3	20.5	19.1	16.0	12.5	10.3	8.4	7.3	11.0	
	12.0			17.6	17.7	18.6	18.5	18.1	18.2	17.4	17.4	15.9	12.5	10.3	8.4	7.3	12.0	
	14.0				14.0	14.2	14.1	13.7	13.8	14.2	14.2	13.6	12.5	10.3	8.4	7.3	14.0	
	16.0				11.0	11.2	11.1	10.8	10.8	11.2	11.3	11.4	10.7	10.2	8.4	7.3	16.0	
	18.0					9.1	9.0	8.7	8.7	9.0	9.1	9.4	9.1	8.8	8.4	7.3	18.0	
	20.0						7.9	7.4	7.0	7.0	7.4	7.5	7.8	7.4	7.1	6.7	6.6	20.0
	22.0							6.0	5.6	5.6	6.1	6.1	6.5	6.1	5.8	5.3	5.3	22.0
	24.0								4.6	4.5	5.0	5.0	5.4	5.0	4.7	4.2	4.2	24.0
	26.0								3.7	3.7	4.1	4.1	4.5	4.1	3.8	3.3	3.3	26.0
	28.0									2.9	3.3	3.4	3.7	3.3	3.0	2.6	2.6	28.0
30.0										2.3	2.7	2.7	3.1	2.7	2.0	1.9	30.0	
32.0											2.2	2.2	2.5	2.1	1.4	1.4	32.0	
34.0											1.8	1.7	2.0	1.7	1.4	0.9	34.0	
36.0												1.3	1.6	1.3	1.0	0.5	36.0	
38.0												1.0	1.3	0.9	0.6		38.0	
40.0													0.9	0.6			40.0	
42.0														0.7			42.0	

※は旋回位置が後方限定の性能を示しています。

ブーム+フルオートラフingジブ(FLJ)作業半径-揚程図

44.9mブーム+フルオートラフingジブ

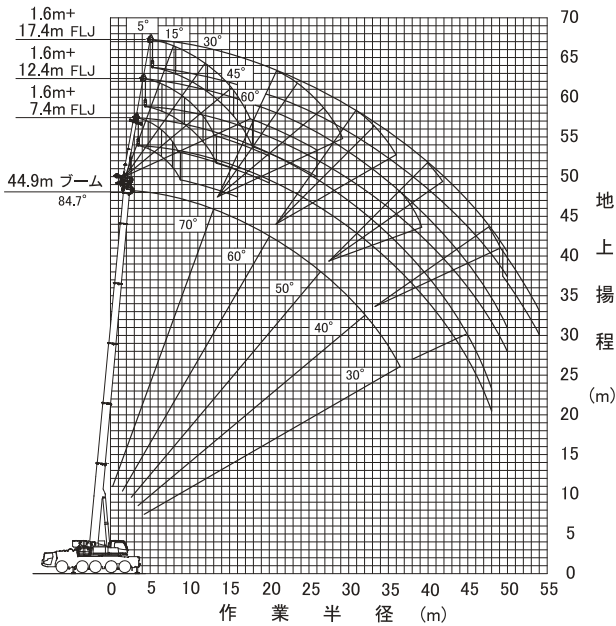

- (注意) 1. 上図はブームおよびジブのたわみを含んでいません。
2. カウンタウエイト34.1t、アウトリガ張出幅7.5m時の性能を図示しています。

52.3mブーム +フルオートラフingジブ

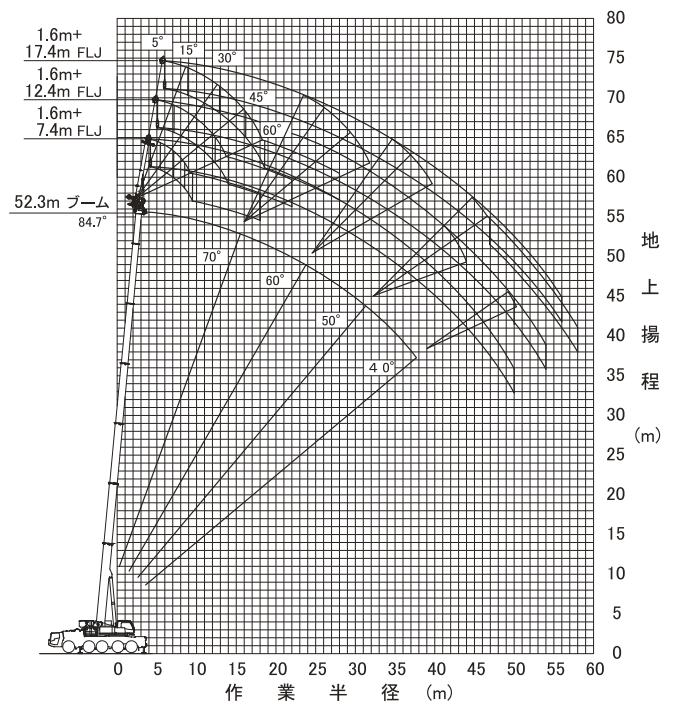

- (注意) 1. 上図はブームおよびジブのたわみを含んでいません。
2. カウンタウエイト34.1t、アウトリガ張出幅7.5m時の性能を図示しています。

56.0mブーム +フルオートラフingジブ

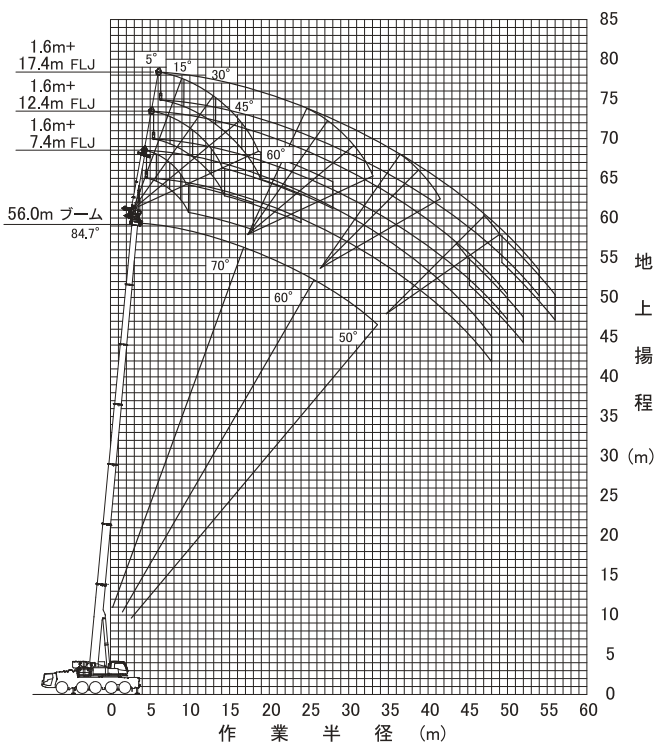

- (注意) 1. 上図はブームおよびジブのたわみを含んでいません。
2. カウンタウエイト34.1t、アウトリガ張出幅7.5m時の性能を図示しています。

60.0mブーム +フルオートラフingジブ

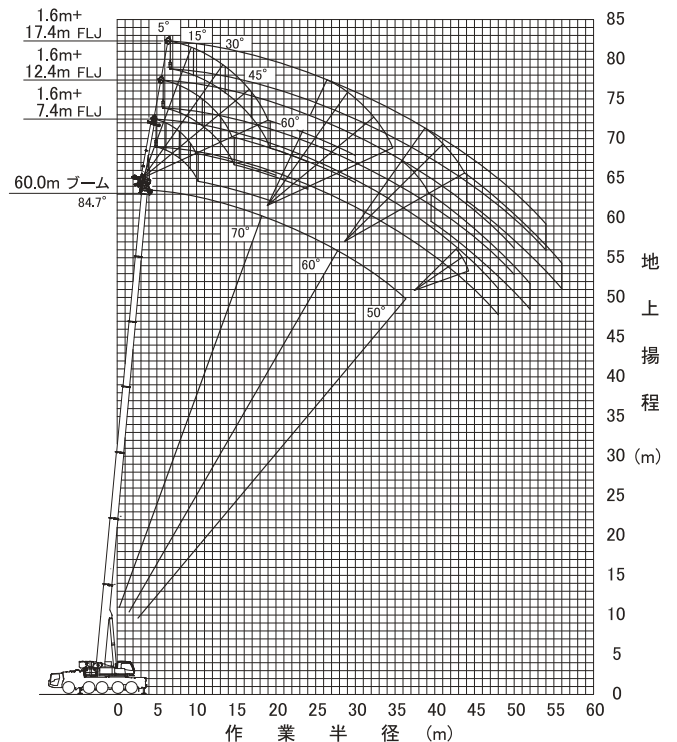

- (注意) 1. 上図はブームおよびジブのたわみを含んでいません。
2. カウンタウエイト34.1t、アウトリガ張出幅7.5m時の性能を図示しています。

フルオートラフィングジブ

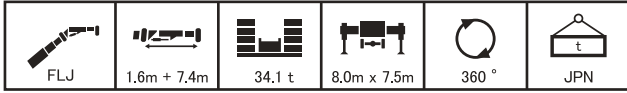

m		44.9					52.3					56.0					60.0					m
°		5	15	30	45	60	5	15	30	45	60	5	15	30	45	60	5	15	30	45	60	°
8.0	6.5																				8.0	
9.0	6.5																				9.0	
10.0	6.5	6.5					4.4														10.0	
11.0	6.5	6.5	6.5				4.4					3.7									11.0	
12.0	6.5	6.5	6.5				4.4					3.7									12.0	
14.0	6.5	6.5	6.5	6.5	4.9		4.4	4.4	4.4			3.7	3.7	3.7							14.0	
16.0	6.5	6.5	6.5	6.3	4.8		4.4	4.4	4.4	4.4	4.4	3.7	3.7	3.7	3.7	3.7					16.0	
18.0	6.5	6.5	6.5	6.1			4.4	4.4	4.4	4.4	4.4	3.7	3.7	3.7	3.7	3.7	3.7				18.0	
20.0	6.5	6.5	6.5	6.0			4.4	4.4	4.4	4.4		3.7	3.7	3.7	3.7						20.0	
22.0	6.5	6.5	6.5	5.9			4.4	4.4	4.4	4.4		3.7	3.7	3.7	3.7						22.0	
24.0	6.3	6.3	6.4	5.8			4.4	4.4	4.4	4.4		3.7	3.7	3.7	3.7						24.0	
26.0	5.8	5.8	5.9	5.7			4.4	4.4	4.2	4.1		3.7	3.7	3.7	3.6						26.0	
28.0	5.3	5.3	5.4	5.5			4.3	4.2	4.0	3.9		3.7	3.6	3.5	3.4						28.0	
30.0	4.8	4.9	4.9				4.1	3.9	3.8	3.7		3.5	3.4	3.3	3.2						30.0	
32.0	4.4	4.4	4.5				3.9	3.7	3.6			3.3	3.2	3.1	3.0						32.0	
34.0	4.0	4.1	4.1				3.7	3.6	3.4			3.1	3.0	2.9							34.0	
36.0	3.4	3.6	3.7				3.4	3.4	3.3			2.9	2.8	2.8							36.0	
38.0	2.8	2.9					3.1	3.2	3.1			2.8	2.7	2.6							38.0	
40.0	2.5	2.5					2.6	2.7	2.9			2.6	2.6	2.5							40.0	
42.0	2.3	2.3					2.5	2.5	2.4			2.3	2.4	2.4							42.0	
44.0	2.2	2.1					2.2	2.3				1.8	1.9	2.0							44.0	
46.0	2.0						1.8	1.9				1.4	1.5								46.0	
48.0	1.9						1.4	1.5				1.0	1.1								48.0	
50.0							1.0	1.1													50.0	

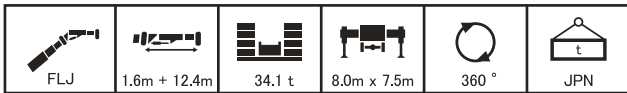

m		44.9					52.3					56.0					60.0					m
°		5	15	30	45	60	5	15	30	45	60	5	15	30	45	60	5	15	30	45	60	°
9.0	4.0																				9.0	
10.0	4.0																				10.0	
11.0	4.0	4.0					3.0														11.0	
12.0	4.0	4.0					3.0					2.6									12.0	
14.0	4.0	4.0					3.0	3.0				2.6	2.6								14.0	
16.0	4.0	4.0	3.7				3.0	3.0	3.0			2.6	2.6								16.0	
18.0	4.0	4.0	3.5	3.0	2.6		3.0	3.0	3.0			2.6	2.6	2.6							18.0	
20.0	4.0	4.0	3.4	2.9	2.6		3.0	3.0	3.0	2.9	2.6	2.6	2.6	2.6	2.6						20.0	
22.0	4.0	3.9	3.2	2.9	2.6		3.0	3.0	3.0	2.8	2.5	2.6	2.6	2.6	2.6	2.5					22.0	
24.0	4.0	3.7	3.1	2.8			3.0	3.0	3.0	2.7		2.6	2.6	2.6	2.6	2.5					24.0	
26.0	4.0	3.6	3.0	2.7			3.0	3.0	3.0	2.7		2.6	2.6	2.6	2.6						26.0	
28.0	4.0	3.5	2.9	2.7			3.0	3.0	2.9	2.6		2.6	2.6	2.6	2.6						28.0	
30.0	3.8	3.3	2.9	2.6			3.0	3.0	2.8	2.5		2.6	2.6	2.6	2.5						30.0	
32.0	3.6	3.2	2.8	2.6			3.0	3.0	2.7	2.5		2.6	2.6	2.6	2.5						32.0	
34.0	3.5	3.1	2.7				3.0	3.0	2.6	2.5		2.6	2.6	2.6	2.4						34.0	
36.0	3.4	3.0	2.6				3.0	2.9	2.6	2.4		2.6	2.6	2.5	2.4						36.0	
38.0	3.2	2.9	2.6				3.0	2.8	2.5			2.5	2.4	2.4	2.3						38.0	
40.0	2.9	2.8	2.5				2.8	2.7	2.5			2.4	2.3	2.2							40.0	
42.0	2.4	2.6	2.5				2.7	2.6	2.4			2.3	2.2	2.1							42.0	
44.0	2.0	2.1					2.2	2.4	2.4			2.2	2.1	2.0							44.0	
46.0	1.9	1.8					2.0	2.0	2.1			1.9	2.0	1.9							46.0	
48.0	1.7	1.7					1.9	1.8	1.8			1.5	1.7	1.8							48.0	
50.0	1.6	1.6					1.6	1.7				1.2	1.3	1.5							50.0	
52.0							1.3	1.4													52.0	
54.0							1.0	1.1													54.0	

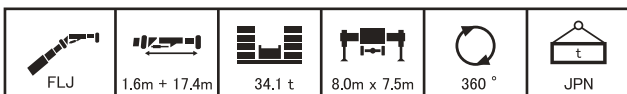





m		44.9					52.3					56.0					60.0					m
°		5	15	30	45	60	5	15	30	45	60	5	15	30	45	60	5	15	30	45	60	°
10.0	2.4																				10.0	
11.0	2.4																				11.0	
12.0	2.4						2.0														12.0	
14.0	2.4	2.4					2.0					1.8									14.0	
16.0	2.4	2.4					2.0	2.0				1.8	1.8								16.0	
18.0	2.4	2.4	2.1				2.0	2.0				1.8	1.8								18.0	
20.0	2.4	2.4	2.0				2.0	2.0	2.0			1.8	1.8								20.0	
22.0	2.4	2.4	2.0	1.7			2.0	2.0	1.9			1.8	1.8	1.8							22.0	
24.0	2.4	2.2	1.9	1.7	1.5		2.0	2.0	1.9	1.7		1.8	1.8	1.8	1.6						24.0	
26.0	2.4	2.2	1.8	1.7	1.5		2.0	2.0	1.8	1.6	1.5	1.8	1.8	1.8	1.6	1.5					26.0	
28.0	2.4	2.1	1.8	1.6			2.0	2.0	1.7	1.6	1.4	1.8	1.8	1.7	1.6	1.4					28.0	
30.0	2.3	2.0	1.7	1.6			2.0	2.0	1.7	1.5		1.8	1.8	1.7	1.5						30.0	
32.0	2.2	1.9	1.7	1.5			2.0	1.9	1.6	1.5		1.8	1.8	1.6	1.5						32.0	
34.0	2.1	1.9	1.6	1.5			2.0	1.8	1.6	1.5		1.8	1.8	1.6	1.5						34.0	
36.0	2.0	1.8	1.6	1.5			2.0	1.8	1.6	1.5		1.8	1.8	1.5	1.4						36.0	
38.0	2.0	1.7	1.5				2.0	1.7	1.5	1.4		1.8	1.7	1.5	1.4						38.0	
40.0	1.9	1.7	1.5				1.9	1.7	1.5	1.4		1.8	1.7	1.5	1.4						40.0	
42.0	1.8	1.6	1.5				1.8	1.6	1.5			1.8	1.6	1.4	1.4						42.0	
44.0	1.8	1.6	1.5				1.8	1.6	1.4			1.8	1.6	1.4							44.0	
46.0	1.7	1.6	1.4				1.7	1.6	1.4			1.7	1.5	1.4							46.0	
48.0	1.7	1.5					1.7	1.5	1.4			1.7	1.5	1.4							48.0	
50.0	1.6	1.5					1.6	1.5	1.4			1.6	1.5	1.3							50.0	
52.0		1.4					1.6	1.4	1.3			1.3	1.4	1.3							52.0	
54.0		1.3					1.4	1.4				1.0	1.2	1.3							54.0	
56.0							1.1	1.3													56.0	
58.0								1.0													58.0	

フルオートラフィングジブ



 FLJ	 1.6m + 7.4m	 22.7 t	 8.0m x 7.5m	 360°	 JPN
---	---	--	---	--	---

m	44.9					52.3					56.0					60.0					m	
	5	15	30	45	60	5	15	30	45	60	5	15	30	45	60	5	15	30	45	60		°
8.0	6.5																				8.0	
9.0	6.5																				9.0	
10.0	6.5	6.5				4.4															10.0	
11.0	6.5	6.5	6.5			4.4															11.0	
12.0	6.5	6.5	6.5			4.4	4.4								3.7						12.0	
14.0	6.5	6.5	6.5	6.5		4.4	4.4	4.4							3.7	3.7					14.0	
16.0	6.5	6.5	6.5	6.3	4.8	4.4	4.4	4.4	4.4	4.4					3.7	3.7	3.7	3.7	3.7		16.0	
18.0	6.5	6.5	6.5	6.1		4.4	4.4	4.4	4.4	4.4					3.7	3.7	3.7	3.7	3.7		18.0	
20.0	6.5	6.5	6.5	6.0		4.4	4.4	4.4	4.4	4.4					3.7	3.7	3.7	3.7	3.7		20.0	
22.0	6.5	6.5	6.5	5.9		4.4	4.4	4.4	4.4	4.4					3.7	3.7	3.7	3.7	3.7		22.0	
24.0	6.3	6.3	6.4	5.8		4.4	4.4	4.4	4.4	4.4					3.7	3.7	3.7	3.7	3.7		24.0	
26.0	5.2	5.5	5.9	5.7		4.4	4.4	4.2	4.1						3.7	3.7	3.7	3.6			26.0	
28.0	4.2	4.4	4.7	4.9		4.3	4.2	4.0	3.9						3.7	3.6	3.5	3.4			28.0	
30.0	3.5	3.5	3.8			3.7	3.9	3.8	3.7						3.5	3.4	3.3	3.2			30.0	
32.0	3.3	3.2	3.1			3.3	3.2	3.4							3.1	3.2	3.1	3.0			32.0	
34.0	3.1	3.0	3.0			2.8	3.0	2.9							2.4	2.6	2.8				34.0	
36.0	2.9	2.9	2.8			2.2	2.4	2.6							1.8	2.0	2.2				36.0	
38.0	2.4	2.5				1.7	1.9	2.0							1.3	1.4	1.6				38.0	
40.0	1.9	2.0				1.2	1.4	1.5							1.0	1.1					40.0	
42.0	1.5	1.6					0.9	1.1														42.0
44.0	1.1	1.2																				44.0

 FLJ	 1.6m + 12.4m	 22.7 t	 8.0m x 7.5m	 360°	 JPN
---	--	--	---	--	---

m	44.9					52.3					56.0					60.0					m	
	5	15	30	45	60	5	15	30	45	60	5	15	30	45	60	5	15	30	45	60		°
9.0	4.0																				9.0	
10.0	4.0																				10.0	
11.0	4.0	4.0				3.0															11.0	
12.0	4.0	4.0				3.0									2.6						12.0	
14.0	4.0	4.0				3.0	3.0								2.6	2.6					14.0	
16.0	4.0	4.0	3.7			3.0	3.0	3.0							2.6	2.6			1.9		16.0	
18.0	4.0	4.0	3.5	3.0	2.6	3.0	3.0	3.0							2.6	2.6	2.6		1.9	1.9	18.0	
20.0	4.0	4.0	3.4	2.9	2.6	3.0	3.0	3.0	2.9	2.6					2.6	2.6	2.6	2.6	1.9	1.9	20.0	
22.0	4.0	3.9	3.2	2.9		3.0	3.0	3.0	2.8	2.5					2.6	2.6	2.6	2.6	2.5	1.9	22.0	
24.0	4.0	3.7	3.1	2.8		3.0	3.0	3.0	2.7						2.6	2.6	2.6	2.6	2.5	1.9	24.0	
26.0	4.0	3.6	3.0	2.7		3.0	3.0	3.0	2.7						2.6	2.6	2.6	2.6		1.9	26.0	
28.0	4.0	3.5	2.9	2.7		3.0	3.0	2.9	2.6						2.6	2.6	2.6	2.6		1.9	28.0	
30.0	3.8	3.3	2.9	2.6		3.0	3.0	2.8	2.5						2.6	2.6	2.6	2.5		1.9	30.0	
32.0	3.3	3.2	2.8	2.6		3.0	3.0	2.7	2.5						2.6	2.6	2.6	2.5		1.9	32.0	
34.0	2.8	2.9	2.7			2.9	3.0	2.6	2.5						2.6	2.6	2.6	2.4		1.9	34.0	
36.0	2.7	2.6	2.6			2.7	2.6	2.6	2.4						2.4	2.6	2.5	2.4		1.9	36.0	
38.0	2.5	2.4	2.4			2.3	2.5	2.4							1.9	2.1	2.4	2.3		1.8	38.0	
40.0	2.3	2.3	2.3			1.8	2.0	2.3							1.4	1.6	1.9			1.3	40.0	
42.0	2.1	2.1	2.1			1.4	1.6	1.8							1.0	1.2	1.5			0.9	42.0	
44.0	1.7	1.8				1.0	1.2	1.4									1.0				44.0	
46.0	1.3	1.4						1.0														46.0
48.0	1.0	1.1																				48.0

 FLJ	 1.6m + 17.4m	 22.7 t	 8.0m x 7.5m	 360°	 JPN
---	--	--	---	--	---

m	44.9					52.3					56.0					60.0					m
	5	15	30	45	60	5	15	30	45	60	5	15	30	45	60	5	15	30	45	60	
10.0	2.4																				10.0
11.0	2.4																				11.0
12.0	2.4					2.0															12.0
14.0	2.4	2.4				2.0									1.8						14.0
16.0	2.4	2.4				2.0	2.0								1.8	1.8				1.0	16.0
18.0	2.4	2.4	2.1			2.0	2.0								1.8	1.8				1.0	18.0
20.0	2.4	2.4	2.0			2.0	2.0	2.0							1.8	1.8				1.0	20.0
22.0	2.4	2.4	2.0	1.7		2.0	2.0	1.9							1.8	1.8	1.8			1.0	22.0
24.0	2.4	2.2	1.9	1.7	1.5	2.0	2.0	1.9	1.7						1.8	1.8	1.8	1.6		1.0	24.0
26.0	2.4	2.2	1.8	1.7	1.5	2.0	2.0	1.8	1.6	1.5					1.8	1.8	1.8	1.6	1.5	1.0	26.0
28.0	2.4	2.1	1.8	1.6		2.0	2.0	1.7	1.6	1.4					1.8	1.8	1.7	1.6	1.4	1.0	28.0
30.0	2.3	2.0	1.7	1.6		2.0	2.0	1.7	1.5						1.8	1.8	1.7	1.5		1.0	30.0
32.0	2.2	1.9	1.7	1.5		2.0	1.9	1.6	1.5						1.8	1.8	1.6	1.5		1.0	32.0
34.0	2.1	1.9	1.6	1.5		2.0	1.8	1.6	1.5						1.8	1.8	1.6	1.5		1.0	34.0
36.0	2.0	1.8	1.6	1.5		2.0	1.8	1.6	1.5						1.8	1.8	1.5	1.4		1.0	36.0
38.0	2.0	1.7	1.5			2.0	1.7	1.5	1.4						1.8	1.7	1.5	1.4		1.0	38.0
40.0	1.8	1.7	1.5			1.8	1.7	1.5	1.4						1.8	1.7	1.5	1.4		1.0	40.0
42.0	1.8	1.6	1.5			1.8	1.6	1.5							1.5	1.6	1.4	1.4		1.0	42.0
44.0	1.7	1.6	1.4			1.5	1.6	1.4							1.1	1.4	1.4			1.0	44.0
46.0	1.7	1.5	1.4			1.1	1.4	1.4									1.3				46.0
48.0	1.5	1.5					1.0	1.3									1.0				48.0
50.0	1.2	1.3						1.0													50.0
52.0		1.0																			52.0

油圧チルトジブ



■ 油圧チルトジブ(HLJ)の構成

記号	名称	長さ
①	ベースジブ	1.1 m+2.6 m
②	ミドルAジブ	6.4 m
③	トップジブ	7.8 m
④	ミドルBジブ	7.0 m

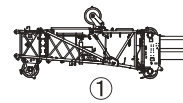

1.1m+ 2.6m ジブ

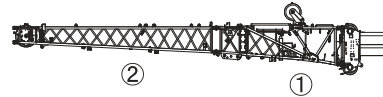

1.1m+ 9.0m ジブ

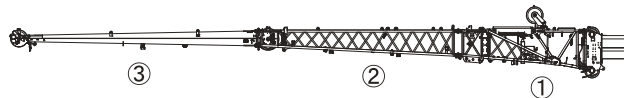

1.1m+16.8m ジブ

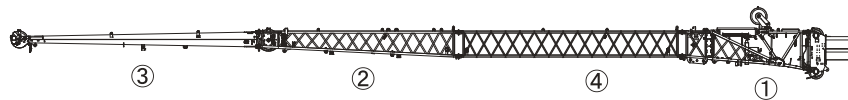

1.1m+23.8m ジブ

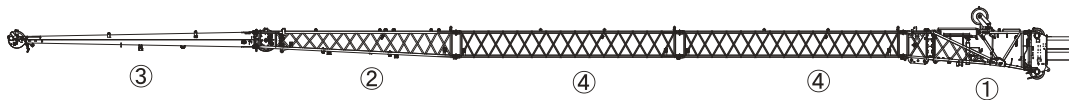

1.1m+30.8m ジブ

ブーム+油圧チルトジブ(HLJ)作業半径－揚程図

44.9mブーム+油圧チルトジブ

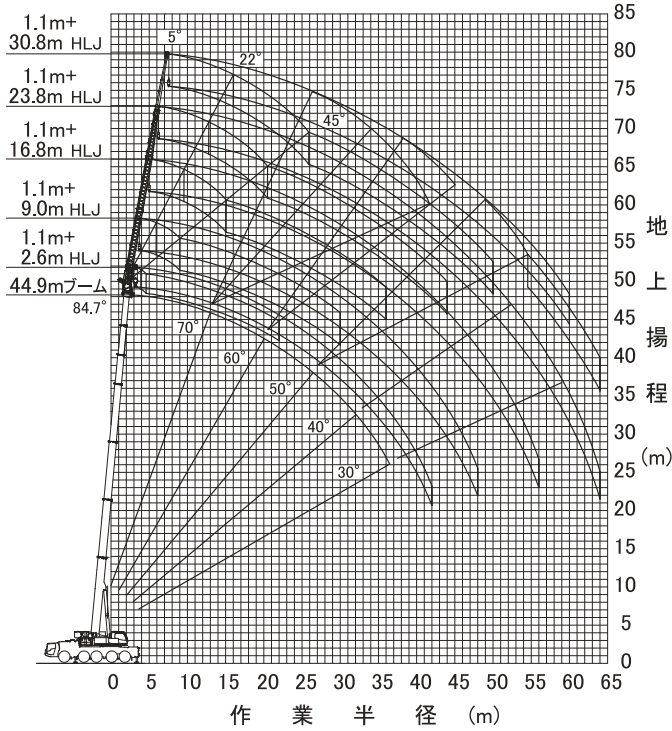

52.3mブーム+油圧チルトジブ

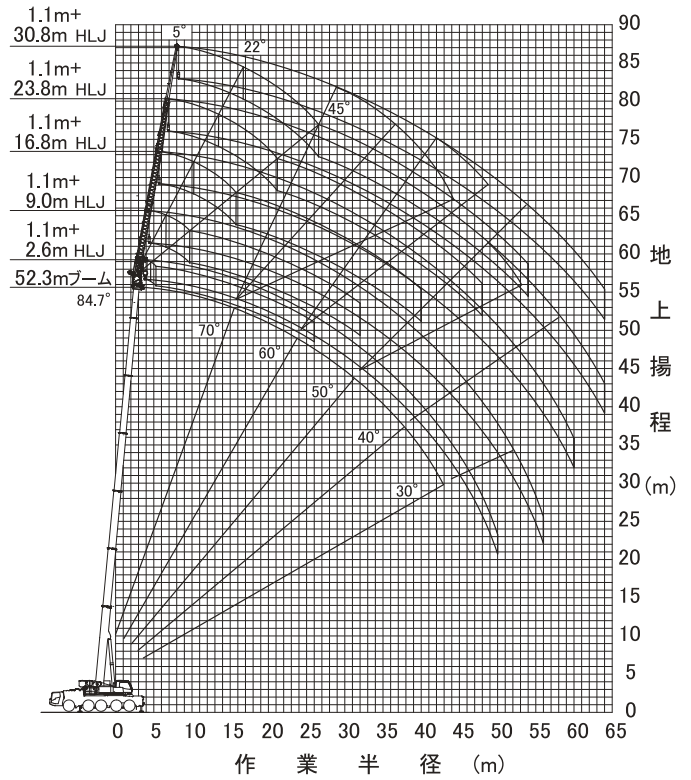

56.0mブーム+油圧チルトジブ

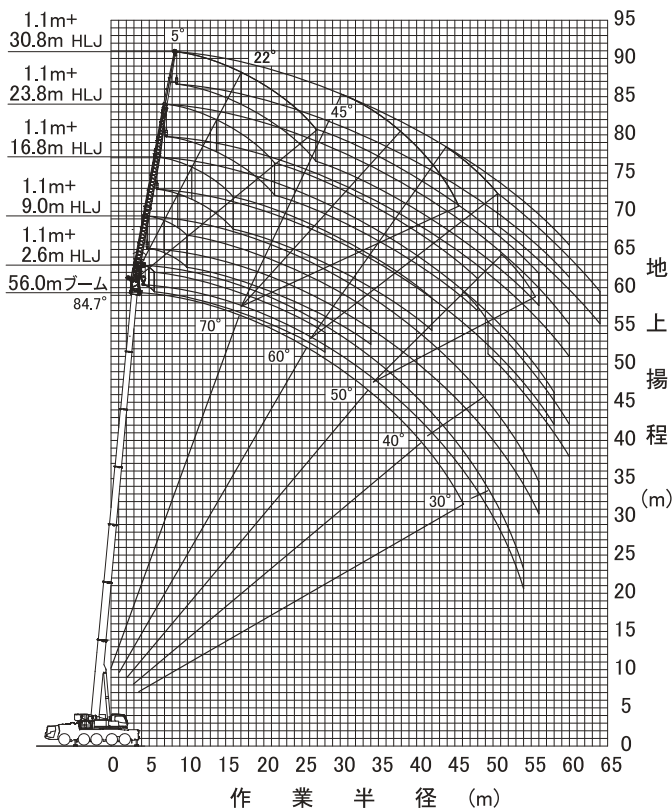

60.0mブーム+油圧チルトジブ

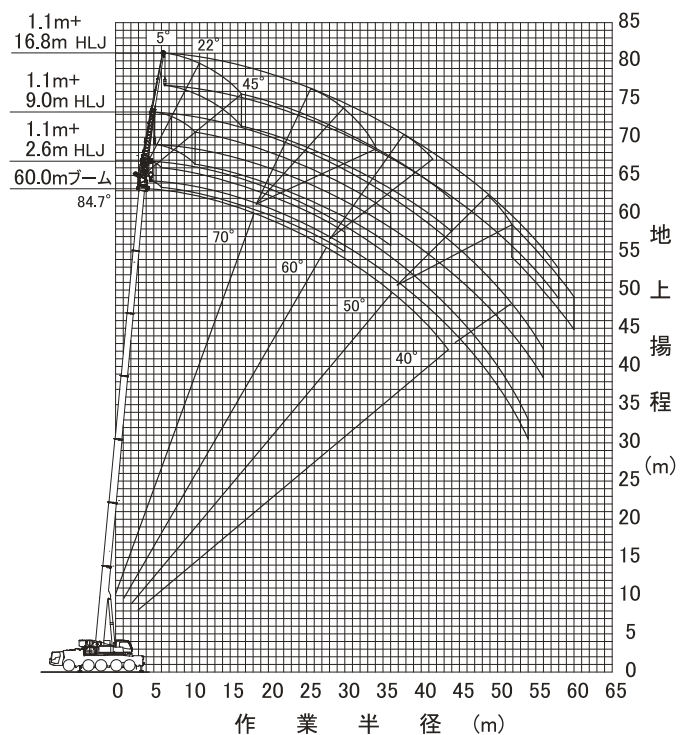

- (注意) 1. 上図はブームおよびジブのたわみを含んでいません。
 2. カウンタウエイト34.1t、アウトリガ張出幅7.5m時の性能を図示しています。

油圧チルトジブ



m	44.9			52.3			56.0			60.0			m	
	°	5	22	45	5	22	45	5	22	45	5	22		45
8.0														8.0
9.0	11.0	11.0	11.0			7.6								9.0
10.0	11.0	11.0	11.0			7.6	7.6			6.3				10.0
11.0	11.0	11.0	11.0		7.6	7.6	7.6			6.3	6.3			11.0
12.0	11.0	11.0	11.0		7.6	7.6	7.6	6.3	6.3	6.3			5.5	12.0
14.0	11.0	11.0	11.0		7.6	7.6	7.6	6.3	6.3	6.3	5.5	5.5	5.5	14.0
16.0	11.0	11.0	11.0		7.6	7.6	7.6	6.3	6.3	6.3	5.5	5.5	5.5	16.0
18.0	11.0	11.0	11.0		7.6	7.6	7.6	6.3	6.3	6.3	5.5	5.5	5.5	18.0
20.0	10.0	10.0	10.1		7.6	7.6	7.6	6.3	6.3	6.3	5.5	5.5	5.5	20.0
22.0	9.2	9.2	9.2		7.6	7.6	7.6	6.3	6.3	6.3	5.5	5.5	5.5	22.0
24.0	8.4	8.4			7.5	7.5	7.6	6.3	6.3	6.3	5.5	5.5	5.5	24.0
26.0	7.7	7.7			6.9	7.0	7.0	6.3	6.3	6.3	5.5	5.5	5.5	26.0
28.0	7.1	7.1			6.6	6.4		6.2	6.2	6.2	5.5	5.5	5.5	28.0
30.0	6.5	6.5			6.2	6.0		5.7	5.8		5.2	5.2	5.1	30.0
32.0	5.7	5.8			5.9	5.7		5.3	5.4		4.9	4.9		32.0
34.0	5.1	5.0			5.5	5.4		5.0	5.0		4.6	4.6		34.0
36.0	4.8	4.7			5.1	5.2		4.6	4.6		4.3	4.3		36.0
38.0	4.6				4.6	4.6		4.2	4.3		4.0	4.0		38.0
40.0	4.4				4.1	4.1		3.6	3.7		3.6	3.6		40.0
42.0	4.1				3.5	3.6		3.1	3.2		3.1	3.1		42.0
44.0					3.1			2.7	2.7		2.6	2.7		44.0
46.0					2.7			2.2	2.3		2.2	2.2		46.0
48.0					2.3			1.9		1.8	1.8			48.0
50.0					2.0			1.5		1.5				50.0
52.0								1.2		1.2				52.0
54.0								0.9		0.9				54.0



m	44.9			52.3			56.0			m			
	°	5	22	45	5	22	45	5	22		45	°	
14.0	1.9												14.0
16.0	1.9					1.9							16.0
18.0	1.9					1.9				1.8			18.0
20.0	1.9	1.9				1.9				1.8			20.0
22.0	1.9	1.9				1.9	1.9			1.8	1.8		22.0
24.0	1.9	1.9				1.9	1.9	1.9		1.8	1.8		24.0
26.0	1.9	1.9				1.9	1.9	1.9		1.8	1.8		26.0
28.0	1.9	1.9	1.9	1.9	1.9	1.9	1.9	1.9		1.8	1.8		28.0
30.0	1.9	1.9	1.9	1.9	1.9	1.9	1.8			1.8	1.8		30.0
32.0	1.9	1.9	1.8	1.9	1.9	1.8	1.8	1.8	1.7	1.8	1.8	1.7	32.0
34.0	1.9	1.9	1.8	1.9	1.9	1.7	1.8	1.8	1.7	1.8	1.8	1.7	34.0
36.0	1.9	1.9	1.8	1.9	1.9	1.7	1.8	1.8	1.7	1.8	1.8	1.7	36.0
38.0	1.9	1.9	1.7	1.9	1.8	1.7	1.8	1.7	1.8	1.8	1.8	1.6	38.0
40.0	1.9	1.8	1.7	1.9	1.8	1.7	1.8	1.7	1.8	1.8	1.8	1.6	40.0
42.0	1.9	1.8	1.7	1.9	1.8	1.6	1.8	1.6	1.8	1.7	1.6	1.6	42.0
44.0	1.9	1.8	1.7	1.9	1.7	1.6	1.8	1.6	1.8	1.7	1.5	1.5	44.0
46.0	1.9	1.7			1.9	1.7	1.6	1.8	1.6	1.8	1.6	1.5	46.0
48.0	1.9	1.7			1.9	1.7	1.6	1.8	1.6	1.8	1.6	1.5	48.0
50.0	1.9	1.7			1.8	1.6		1.8	1.6		1.8	1.6	50.0
52.0	1.8	1.6			1.8	1.6		1.8	1.6		1.8	1.6	52.0
54.0	1.5	1.6			1.7	1.6		1.6	1.5		1.6	1.5	54.0
56.0	1.4	1.6			1.6	1.6		1.4	1.5		1.4	1.5	56.0
58.0	1.3				1.5	1.4		1.1	1.5		1.1	1.5	58.0
60.0	1.2				1.2	1.4		0.8	1.2		0.8	1.2	60.0
64.0	1.1				0.8								64.0



m	44.9			52.3			56.0			60.0			m	
	°	5	22	45	5	22	45	5	22	45	5	22		45
10.0			5.0											10.0
11.0			5.0											11.0
12.0			5.0			4.8								12.0
14.0			5.0	5.0		4.8				4.0				14.0
16.0	5.0	5.0	5.0		4.8	4.8				4.0	4.0		3.6	16.0
18.0	5.0	5.0	5.0	4.8	4.8	4.8				4.0	4.0		3.6	18.0
20.0	5.0	5.0	5.0	4.8	4.8	4.8				4.0	4.0	4.0	3.6	20.0
22.0	5.0	5.0	5.0	4.8	4.8	4.8				4.0	4.0	4.0	3.6	22.0
24.0	5.0	5.0	5.0	4.8	4.8	4.8				4.0	4.0	4.0	3.6	24.0
26.0	5.0	5.0	5.0	4.8	4.8	4.8				4.0	4.0	4.0	3.6	26.0
28.0	5.0	5.0	5.0	4.8	4.8	4.8				4.0	4.0	4.0	3.6	28.0
30.0	5.0	5.0	5.0	4.8	4.8	4.8				4.0	4.0	4.0	3.6	30.0
32.0	5.0	5.0		4.7	4.7	4.8				4.0	4.0	4.0	3.6	32.0
34.0	4.8	4.9		4.4	4.4					4.0	4.0	4.0	3.6	34.0
36.0	4.5	4.6		4.3	4.1					3.9	4.0		3.5	36.0
38.0	4.1	4.2		4.2	3.9					3.7	3.7		3.3	38.0
40.0	3.6	3.8		4.0	3.7					3.4	3.5		3.1	40.0
42.0	3.4	3.3		3.8	3.6					3.2	3.3		3.0	42.0
44.0	3.3			3.4	3.4					3.0	3.1		2.8	44.0
46.0	3.1			3.0	3.1					2.5	2.7		2.5	46.0
48.0	3.0			2.6	2.7					2.2	2.3		2.1	48.0
50.0				2.2						1.8	2.0		1.7	50.0
52.0				1.9						1.5	1.6		1.4	52.0
54.0				1.6						1.2			1.1	54.0
56.0				1.3						0.9			0.8	56.0



m	44.9			52.3			56.0			m			
	°	5	22	45	5	22	45	5	22		45	°	
16.0	1.5												16.0
18.0	1.5					1.5							18.0
20.0	1.5					1.5				1.4			20.0
22.0	1.5					1.5				1.4			22.0
24.0	1.5	1.5				1.5				1.4			24.0
26.0	1.5	1.5				1.5	1.5			1.4			26.0
28.0	1.5	1.5				1.5	1.5			1.4	1.4		28.0
30.0	1.5	1.5				1.5	1.5			1.4	1.4		30.0
32.0	1.5	1.5				1.5	1.5			1.4	1.4		32.0
34.0	1.5	1.5	1.4	1.5	1.5					1.4	1.4		34.0
36.0	1.5	1.5	1.3	1.5	1.5	1.3				1.4	1.4		36.0
38.0	1.5	1.5	1.3	1.5	1.5	1.3	1.4	1.4	1.2	1.4	1.4	1.2	38.0
40.0	1.5	1.5	1.2	1.5	1.5	1.2	1.4	1.4	1.2	1.4	1.4	1.2	40.0
42.0	1.5	1.5	1.2	1.5	1.5	1.2	1.4	1.4	1.2	1.4	1.4	1.2	42.0
44.0	1.5	1.5	1.1	1.5	1.5	1.1	1.4	1.4	1.1	1.4	1.4	1.1	44.0
46.0	1.5	1.5	1.1	1.5	1.5	1.1	1.4	1.4	1.1	1.4	1.4	1.1	46.0
48.0	1.5	1.5	1.1	1.5	1.5	1.1	1.4	1.4	1.1	1.4	1.4	1.1	48.0
50.0	1.5	1.4	1.0	1.5	1.4	1.0	1.4	1.4	1.0	1.4	1.4	1.0	50.0
52.0	1.5	1.4		1.5	1.4	1.0	1.4	1.3	1.0	1.4	1.3	1.0	52.0
54.0	1.4	1.3		1.5	1.3	1.0	1.4	1.2	1.0	1.4	1.2	1.0	54.0
56.0	1.4	1.3		1.4	1.3		1.3	1.2	0.9	1.4	1.2	0.9	56.0
58.0	1.1	1.2		1.1	1.2		1.2	1.1		1.2	1.1		58.0
60.0	0.9	1.2		1.0	1.2		0.9	1.0		1.0	1.0		60.0
64.0		0.8		0.8	0.8					0.8			64.0



m	44.9			52.3			56.0			60.0			m	
	°	5	22	45	5	22	45	5	22	45	5	22		45
11.0	2.8													11.0
12.0	2.8													12.0
14.0	2.8				2.8			2.5						14.0
16.0	2.8	2.8			2.8			2.5				2.3		16.0
18.0	2.8	2.7			2.8									

油圧チルトジブ



HLJ	1.1m + 2.6m	22.7 t	8.0m x 7.5m	360°	JPN

		44.9			52.3			56.0			60.0				
		5	22	45	5	22	45	5	22	45	5	22	45		
	8.0														8.0
	9.0	11.0	11.0	11.0			7.6								9.0
	10.0	11.0	11.0	11.0			7.6	7.6			6.3				10.0
	11.0	11.0	11.0	11.0	7.6	7.6	7.6			6.3	6.3			5.5	11.0
	12.0	11.0	11.0	11.0	7.6	7.6	7.6	6.3	6.3	6.3				5.5	12.0
	14.0	11.0	11.0	11.0	7.6	7.6	7.6	6.3	6.3	6.3	5.5	5.5	5.5	5.5	14.0
	16.0	11.0	11.0	11.0	7.6	7.6	7.6	6.3	6.3	6.3	5.5	5.5	5.5	5.5	16.0
	18.0	11.0	11.0	11.0	7.6	7.6	7.6	6.3	6.3	6.3	5.5	5.5	5.5	5.5	18.0
	20.0	10.0	10.0	10.1	7.6	7.6	7.6	6.3	6.3	6.3	5.5	5.5	5.5	5.5	20.0
	22.0	8.5	8.7	8.8	7.6	7.6	7.6	6.3	6.3	6.3	5.5	5.5	5.5	5.5	22.0
	24.0	7.2	7.3		7.5	7.5	7.6	6.3	6.3	6.3	5.5	5.5	5.5	5.5	24.0
	26.0	6.4	6.3		6.8	6.8	6.6	6.3	6.3	6.3	5.5	5.5	5.5	5.5	26.0
	28.0	6.0	5.9		5.9	6.0		5.6	5.7	5.8	5.5	5.5	5.5	5.5	28.0
	30.0	5.7	5.6		5.1	5.2		4.7	4.8		4.6	4.7	4.8		30.0
	32.0	5.0	5.0		4.3	4.4		3.9	4.0		3.9	4.0			32.0
	34.0	4.3	4.4		3.7	3.7		3.2	3.3		3.2	3.3			34.0
	36.0	3.7	3.8		3.1	3.1		2.7	2.7		2.6	2.7			36.0
38.0	3.2			2.6	2.6		2.1	2.2		2.1	2.2			38.0	
40.0	2.8			2.1	2.1		1.7	1.7		1.6	1.7			40.0	
42.0	2.3			1.7	1.7		1.3	1.3		1.2	1.3			42.0	
44.0				1.3			0.9	0.9		0.8	0.9			44.0	
46.0				1.0										46.0	

HLJ	1.1m + 23.8m	22.7 t	8.0m x 7.5m	360°	JPN

		44.9			52.3			56.0				
		5	22	45	5	22	45	5	22	45		
	14.0	1.9										14.0
	16.0	1.9					1.9					16.0
	18.0	1.9					1.9			1.8		18.0
	20.0	1.9	1.9				1.9			1.8		20.0
	22.0	1.9	1.9				1.9	1.9		1.8	1.8	22.0
	24.0	1.9	1.9				1.9	1.9		1.8	1.8	24.0
	26.0	1.9	1.9				1.9	1.9		1.8	1.8	26.0
	28.0	1.9	1.9	1.9	1.9	1.9	1.9	1.9	1.9	1.8	1.8	28.0
	30.0	1.9	1.9	1.9	1.9	1.9	1.9	1.8	1.8	1.8	1.8	30.0
	32.0	1.9	1.9	1.8	1.9	1.9	1.8	1.8	1.8	1.8	1.7	32.0
	34.0	1.9	1.9	1.8	1.9	1.9	1.7	1.8	1.8	1.7	1.7	34.0
	36.0	1.9	1.9	1.8	1.9	1.9	1.7	1.8	1.8	1.7	1.7	36.0
	38.0	1.9	1.9	1.7	1.9	1.8	1.7	1.8	1.8	1.7	1.6	38.0
	40.0	1.9	1.8	1.7	1.9	1.8	1.7	1.8	1.8	1.7	1.6	40.0
	42.0	1.9	1.8	1.7	1.9	1.8	1.6	1.8	1.8	1.7	1.6	42.0
	44.0	1.9	1.8	1.7	1.9	1.7	1.6	1.7	1.7	1.6	1.6	44.0
	46.0	1.9	1.7	1.6	1.8	1.7	1.6	1.7	1.6	1.6	1.5	46.0
48.0	1.8	1.6		1.4	1.6	1.6	1.0	1.6	1.5		48.0	
50.0	1.7	1.6		1.1	1.6			1.2			50.0	
52.0	1.5	1.6		0.9	1.3			0.9			52.0	
54.0	1.2	1.4			1.0						54.0	
56.0	1.0	1.2									56.0	
58.0	0.8										58.0	

HLJ	1.1m + 9.0m	22.7 t	8.0m x 7.5m	360°	JPN

		44.9			52.3			56.0			60.0				
		5	22	45	5	22	45	5	22	45	5	22	45		
	10.0		5.0												10.0
	11.0		5.0												11.0
	12.0		5.0				4.8								12.0
	14.0		5.0	5.0			4.8			4.0					14.0
	16.0	5.0	5.0	5.0			4.8	4.8		4.0	4.0			3.6	16.0
	18.0	5.0	5.0	5.0	4.8	4.8	4.8			4.0	4.0			3.6	18.0
	20.0	5.0	5.0	5.0	4.8	4.8	4.8	4.0	4.0	4.0	3.6	3.6	3.6	3.6	20.0
	22.0	5.0	5.0	5.0	4.8	4.8	4.8	4.0	4.0	4.0	3.6	3.6	3.6	3.6	22.0
	24.0	5.0	5.0	5.0	4.8	4.8	4.8	4.0	4.0	4.0	3.6	3.6	3.6	3.6	24.0
	26.0	5.0	5.0	5.0	4.8	4.8	4.8	4.0	4.0	4.0	3.6	3.6	3.6	3.6	26.0
	28.0	5.0	5.0	5.0	4.8	4.8	4.8	4.0	4.0	4.0	3.6	3.6	3.6	3.6	28.0
	30.0	4.8	5.0	5.0	4.8	4.8	4.8	4.0	4.0	4.0	3.6	3.6	3.6	3.6	30.0
	32.0	4.5	4.3		4.3	4.5	4.8	4.0	4.0	4.0	3.6	3.6	3.6	3.6	32.0
	34.0	4.3	4.0		4.0	4.3		3.6	4.0	4.0	3.5	3.6	3.5	3.4	34.0
	36.0	4.0	3.8		3.4	3.7		3.0	3.3		2.9	3.3	3.4		36.0
	38.0	3.5	3.6		2.9	3.2		2.5	2.8		2.4	2.7			38.0
	40.0	3.1	3.3		2.4	2.7		2.0	2.3		1.9	2.2			40.0
42.0	2.6	2.8		2.0	2.2		1.6	1.8		1.5	1.8			42.0	
44.0	2.3			1.6	1.8		1.2	1.4		1.1	1.4			44.0	
46.0	1.9			1.3	1.4		0.9	1.1		0.8	1.0			46.0	
48.0	1.6			1.0	1.1									48.0	

HLJ	1.1m + 30.8m	22.7 t	8.0m x 7.5m	360°	JPN

		44.9			52.3			56.0				
		5	22	45	5	22	45	5	22	45		
	16.0	1.5										16.0
	18.0	1.5					1.5					18.0
	20.0	1.5					1.5			1.4		20.0
	22.0	1.5					1.5			1.4		22.0
	24.0	1.5	1.5				1.5			1.4		24.0
	26.0	1.5	1.5				1.5	1.5		1.4		26.0
	28.0	1.5	1.5				1.5	1.5		1.4	1.4	28.0
	30.0	1.5	1.5				1.5	1.5	1.4	1.4	1.4	30.0
	32.0	1.5	1.5				1.5	1.5		1.4	1.4	32.0
	34.0	1.5	1.5	1.4	1.5	1.5				1.4	1.4	34.0
	36.0	1.5	1.5	1.3	1.5	1.5	1.3	1.4	1.4			36.0
	38.0	1.5	1.5	1.3	1.5	1.5	1.3	1.4	1.4	1.2		38.0
	40.0	1.5	1.5	1.2	1.5	1.5	1.2	1.4	1.4	1.2	1.2	40.0
	42.0	1.5	1.5	1.2	1.5	1.5	1.2	1.4	1.4	1.2	1.2	42.0
	44.0	1.5	1.5	1.1	1.5	1.5	1.1	1.4	1.4	1.1	1.1	44.0
	46.0	1.5	1.5	1.1	1.4	1.5	1.1	1.4	1.4	1.1	1.1	46.0
	48.0	1.4	1.5	1.1	1.4	1.5	1.1	1.1	1.4	1.1	1.1	48.0
50.0	1.3	1.4	1.0	1.2	1.4	1.0	0.8	1.4	1.0	1.0	50.0	
52.0	1.2	1.2		0.9	1.3	1.0		1.1	1.0	1.0	52.0	
54.0	1.1	1.1			1.2	1.0		0.8	1.0	1.0	54.0	
56.0	1.0	1.0			0.9			0.9		0.9	56.0	
58.0	0.8	0.9									58.0	
60.0		0.8									60.0	

HLJ	1.1m + 16.8m	22.7 t	8.0m x 7.5m	360°	JPN

		44.9			52.3			56.0			60.0					
		5	22	45	5	22	45	5	22	45	5	22	45			
	11.0	2.8													11.0	
	12.0	2.8													12.0	
	14.0	2.8						2.5							14.0	
	16.0	2.8	2.8					2.5					2.3		16.0	
	18.0	2.8	2.7					2.5	2.4				2.3	2.3	18.0	
	20.0	2.8	2.6	2.1				2.5	2.4				2.3	2.3	20.0	
	22.0	2.8	2.5	2.0				2.5	2.3				2.3	2.3	22.0	
	24.0	2.8	2.4	2.0				2.5	2.3	1.9			2.3	2.2	24.0	
	26.0	2.8	2.3	1.9				2.5	2.2	1.9			2.3	2.2	1.9	26.0
	28.0	2.7	2.2	1.9				2.5	2.1	1.8			2.3	2.1	1.8	28.0
	30.0	2.6	2.1	1.9				2.5	2.1	1.8			2.3	2.0	1.8	30.0
	32.0	2.5	2.1	1.8				2.4	2.0	1.8			2.3	2.0	1.7	32.0
	34.0	2.4	2.0	1.												